

Absolute encoders - bus interfaces

Solid shaft with clamping or synchro flange

Optical multiturn encoders 13 bit ST / 16 bit MT, CANopen®

GXP5W - CANopen®



GXP5W with clamping flange

Features

- Encoder multiturn / CANopen®
- Optical sensing method
- Resolution: singleturn 13 bit, multiturn 16 bit
- Clamping or synchro flange
- LED status indicator
- CANopen® Profile CIA DSP 406 / DSP 417 Lift
- Permanent check of code continuity
- Maximum resistant against magnetic fields

Optional

- Corrosion protection for offshore applications

Technical data - electrical ratings

Voltage supply	10...30 VDC
Reverse polarity protection	Yes
Consumption w/o load	≤50 mA (24 VDC)
Initializing time typ.	250 ms after power on
Interfaces	CANopen®, CANopen®-Lift
Function	Multiturn
Transmission rate	10...1000 kBaud
Profile conformity	CANopen® CiA DSP 406 V 3.0 CANopen® CiA DSP 417 Lift
Operating mode	Event-triggered / Time-triggered Remotely-requested Sync (cyclic) / Sync (acyclic)
Identifier	11 bit
Steps per turn	≤8192 / 13 bit
Number of turns	≤65536 / 16 bit
Absolute accuracy	±0.025 °
Sensing method	Optical
Code	Binary
Code sequence	CW/CCW programmable
Output stages	CAN bus standard ISO / DIS 11898
Interference immunity	DIN EN 61000-6-2
Emitted interference	DIN EN 61000-6-4
Programmable parameters	Operating modes Total resolution Scaling Rotation speed monitoring
Diagnostic functions	Position or parameter error Multiturn sensing
Status indicator	DUO-LED integrated in housing
Approval	UL approval / E63076

Technical data - mechanical design

Size (flange)	ø58 mm
Shaft type	ø10 mm solid shaft (clamping flange) ø6 mm solid shaft (synchro flange)
Flange	Clamping or synchro flange
Protection DIN EN 60529	IP 54 (without shaft seal), IP 65 (with shaft seal)
Operating speed	≤10000 rpm (mechanical) ≤6000 rpm (electric)
Starting acceleration	≤1000 U/s ²
Starting torque	≤0.015 Nm (+25 °C, IP 54) ≤0.03 Nm (+25 °C, IP 65)
Rotor moment of inertia	20 gcm ²
Admitted shaft load	≤20 N axial ≤40 N radial
Materials	Housing: steel Flange: aluminium
Operating temperature	-25...+85 °C -40...+85 °C (optional)
Relative humidity	95 % non-condensing
Resistance	DIN EN 60068-2-6 Vibration 10 g, 16-2000 Hz DIN EN 60068-2-27 Shock 200 g, 6 ms
Weight approx.	500 g
Connection	Connector M12, 5-pin Connector M23, 12-pin Connector D-SUB, 9-pin

· Subject to modification in technic and design. Errors and omissions excepted.

Absolute encoders - bus interfaces

Solid shaft with clamping or synchro flange

Optical multiturn encoders 13 bit ST / 16 bit MT, CANopen®

GXP5W - CANopen®

Part number

GXP5W. 10

Interface

- 05 CANopen® Lift DSP 417 / galvanically isolated
- 06 CANopen® DSP 406 / galvanically isolated
- 15 CANopen® Lift DSP 417 / not galvanically isolated
- 16 CANopen® DSP 406 / not galvanically isolated

Connection

- A3 Connector M23, 12-pin, radial
- D3 Connector D-SUB, 9-pin, radial
- M1 Connector M12, 5-pin, radial
- M2 Connector 2 x M12, 5-pin axial
- M3 Connector 2 x M12, 5-pin radial

Voltage supply

- 10 10...30 VDC

Flange / Solid shaft

- 0 Clamping flange / ø10 mm, IP 54
- A Clamping flange / ø10 mm, IP 65
- 1 Synchro flange / ø6 mm, IP 54
- B Synchro flange / ø6 mm, IP 65

Accessories

Connectors and cables

Z 148.001	Female connector M23, 12-pin, without cable
Z 148.003	Female connector M23, 12-pin, 2 m cable
Z 148.005	Female connector M23, 12-pin, 5 m cable
Z 148.007	Female connector M23, 12-pin, 10 m cable
Z 180.003	Female connector M12, 5-pin, A-coded, 2 m cable
Z 180.005	Female connector M12, 5-pin, A-coded, 5 m cable
Z 180.007	Female connector M12, 5-pin, A-coded, 10 m cable
Z 181.005	Cable connector M12, 5-pin, A-coded, 5 m cable, CANopen®, connection continuative bus

Mounting accessories

Z 119.006	Eccentric fixing, single
Z 119.013	Adaptor plate for clamping flange for modification into synchro flange
Z 119.015	Mounting adaptor for synchro flange
Z 119.017	Mounting adaptor for clamping flange (M3)
Z 119.035	Bearing flange for encoders with synchro flange

Absolute encoders - bus interfaces

Solid shaft with clamping or synchro flange

Optical multiturn encoders 13 bit ST / 16 bit MT, CANopen®

GXP5W - CANopen®

Terminal significance

UB	Encoder voltage supply
GND B	Encoder ground connection relating to UB
CAN_L	CAN bus signal (dominant Low)
CAN_H	CAN bus signal (dominant High)
CAN_GND	GND relating to CAN interface. Depending on model separated from GND B either by galvanic isolation or by inductive earthing.

CANopen® features

Bus protocol	CANopen®
Device profile	CANopen® - CiA DSP 406, V 3.0 (Device Class 2, CAN 2.0B)
Operating modes	Event-triggered / Time-triggered Remotely-requested Sync (cyclic) / Sync (acyclic)
Preset	Parameter for setting the encoder to a requested position value assigned to a defined shaft position of the system. The offset of encoder zero point and mechanical zero point is stored in the encoder.
Rotating direction	Parameter for defining the rotating direction in which there have to be ascending or descending position values.
Scaling	Parameter defining the steps per turn as well as the total resolution.
Diagnosis	The encoder supports the following error warnings: - Position and parameter error - Lithium battery voltage control (Multiturn)
Node Monitoring	Heartbeat or Nodeguarding
Default	50 kbit/s, Node ID 1

Terminal assignment

Connector M12

Connector	Core colour	Assignment
Pin 1	brown	GND B
Pin 2	white	UB
Pin 3	blue	CAN_GND
Pin 4	black	CAN_H
Pin 5	grey	CAN_L

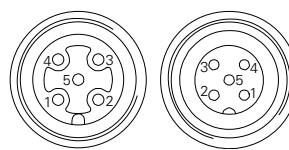

Please use cores twisted in pairs (for example CAN_H / CAN_L) for extension cables of more than 10 m length.

Connector D-SUB

Connector	Assignment
Pin 1	–
Pin 2	CAN_L
Pin 3	CAN_GND
Pin 4	–
Pin 5	–
Pin 6	GND B
Pin 7	CAN_H
Pin 8	–
Pin 9	UB

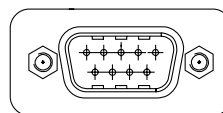

Please use cores twisted in pairs (for example CAN_H / CAN_L) for extension cables of more than 10 m length.

Connector M23

Connector	Core colour	Assignment
Pin 1	brown/green	UB
Pin 2	white/green	GND B
Pin 3	pink	CAN_L
Pin 4	grey	CAN_H
Pin 5	white	CAN_GND
Pin 6-12	–	–

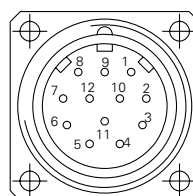

Please use cores twisted in pairs (for example CAN_H / CAN_L) for extension cables of more than 10 m length.

Absolute encoders - bus interfaces

Solid shaft with clamping or synchro flange

Optical multiturn encoders 13 bit ST / 16 bit MT, CANopen®

GXP5W - CANopen®

Dimensions

GXP5W - clamping flange and connector M23

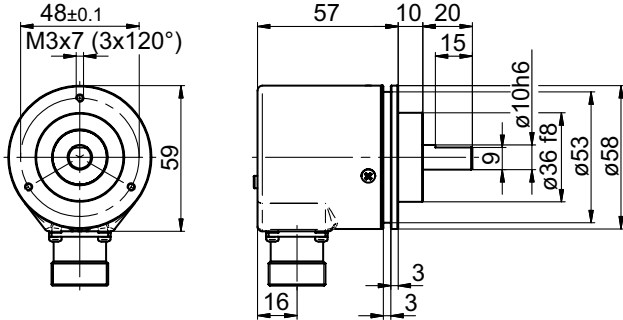

GXP5W - clamping flange and connector M12

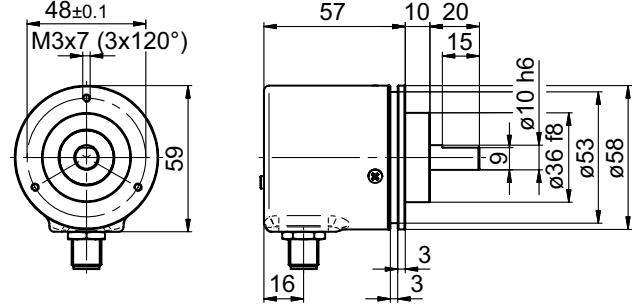

GXP5W - clamping flange and D-SUB

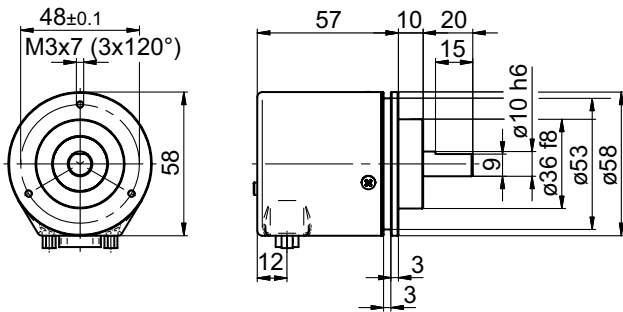

GXP5W - clamping flange, 2 x connector M12, radial

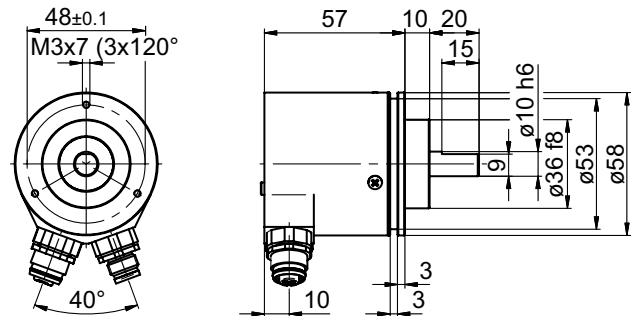

GXP5W - clamping flange, 2 x connector M12, axial

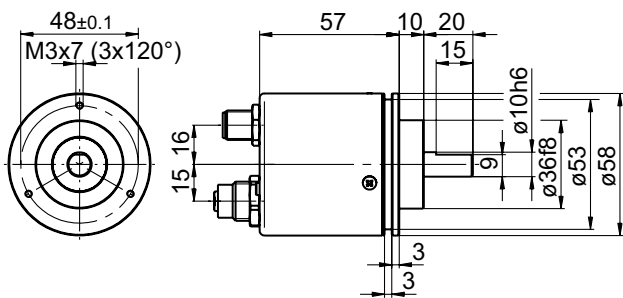

GXP5W - connector dimensions

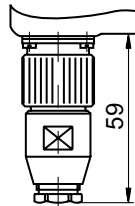

GXP5W - synchro flange

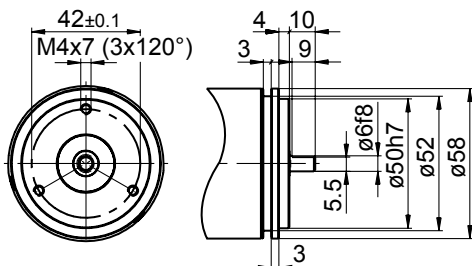

· Subject to modification in technic and design. Errors and omissions excepted.